

LH0002 Buffer

General Description

The LH0002 is a general purpose buffer. Its features make it ideal to integrate with operational amplifiers inside a closed loop configuration to increase current output. The symmetrical output portion of the circuit also provides a low output impedance for both the positive and negative slopes of output pulses.

The LH0002 is available in an 8-lead TO-99 can. The LH0002C is available in an 8-lead TO-99, and a 10-pin molded dual-in-line package.

The LH0002 is specified for operation over the -55°C to $+125^{\circ}\text{C}$ military temperature range. The LH0002C is specified for operation over the 0°C to $+85^{\circ}\text{C}$ temperature range.

Features

- High input impedance 400 k Ω
- Low output impedance 6 Ω
- High power efficiency
- Low harmonic distortion
- DC to 30 MHz bandwidth
- Output voltage swing that approaches supply voltage
- 400 mA pulsed output current
- Slew rate is typically 200 V/ μs
- Operation from $\pm 5\text{V}$ to $\pm 20\text{V}$

Applications

- Line driver
- 30 MHz buffer
- High speed D/A conversion

Schematic and Connection Diagrams

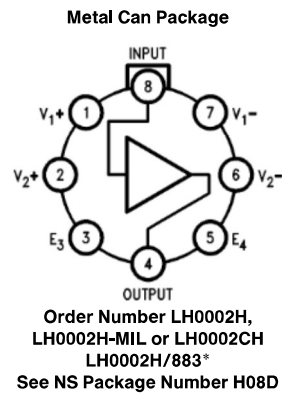
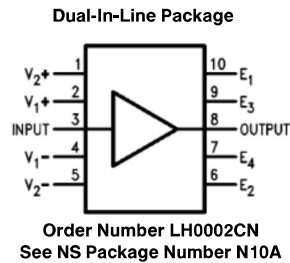
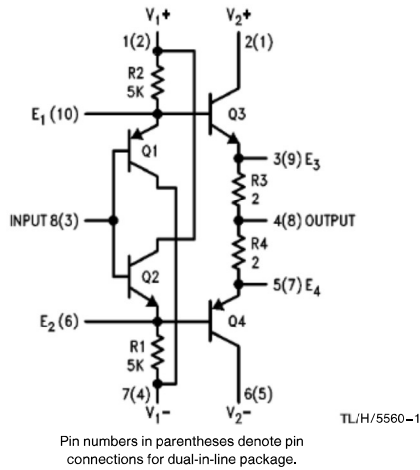

*Available per SMD #7801301

Absolute Maximum Ratings (Note 3)

If Military/Aerospace specified devices are required, please contact the National Semiconductor Sales Office/Distributors for availability and specifications.

(Note 2)

Supply Voltage	± 22V
Power Dissipation (Note 4)	600 mW
Input Voltage	(Equal to Power Supply Voltage)
Storage Temperature Range	− 65°C to + 150°C
Junction Temperature	
N Package	+ 150°C
H Package	+ 175°C
Steady State Output Current	± 100 mA
Pulsed Output Current (50 ms On/1 sec. Off)	± 400 mA
Lead Temperature Soldering (10 seconds)	
Metal Can	300°C
Plastic	260°C
ESD Rating (Note 6)	2 kV

Operating Ratings (Note 3)

Temperature Range	
LH0002	− 55°C to + 125°C
LH0002C	0°C to + 85°C
Thermal Resistance (Note 5)	
θ_{JA} , H Package	+ 125°C/W
θ_{JC} , H Package	+ 75°C/W
θ_{JA} , N Package	+ 120°C/W

Electrical Characteristics (Note 1)

Parameter	Conditions	Min	Typ	Max	Units
Voltage Gain	$R_S = 10\text{ k}\Omega$, $R_L = 1.0\text{ k}\Omega$, $V_{IN} = \pm 10\text{V}$	0.95	0.97		
Input Impedance	$R_S = 200\text{ k}\Omega$, $V_{IN} = \pm 1.0\text{V}$, $R_L = 1.0\text{ k}\Omega$	180	400		k Ω
Output Impedance	$V_{IN} = \pm 1.0\text{V}$, $R_L = 50\Omega$, $R_S = 10\text{ k}\Omega$		6.0	10	Ω
Output Voltage Swing	$R_L = 1.0\text{ k}\Omega$, $V_{IN} = \pm 12\text{V}$	± 10	± 11		V
Output Voltage Swing	$V_S = \pm 15\text{V}$, $V_{IN} = \pm 12\text{V}$, $R_S = 50\Omega$, $R_L = 100\Omega$, $T_A = 25^\circ\text{C}$	± 10			V
DC Output Offset Voltage	$R_S = 300\Omega$, $R_L = 1.0\text{ k}\Omega$		± 10	± 30	mV
DC Input Bias Current	$R_S = 10\text{ k}\Omega$, $R_L = 1.0\text{ k}\Omega$		± 6.0	± 10	μA
Harmonic Distortion	$V_{IN} = 5.0\text{ V}_{\text{rms}}$, $f = 1.0\text{ kHz}$		0.1		%
Rise Time	$R_L = 50\Omega$, $\Delta V_{IN} = 100\text{ mV}$		7.0	12	ns
Positive Supply Current	$R_S = 10\text{ k}\Omega$, $R_L = 1.0\text{ k}\Omega$		+ 6.0	+ 10	mA
Negative Supply Current	$R_S = 10\text{ k}\Omega$, $R_L = 1.0\text{ k}\Omega$		− 6.0	− 10	mA

Note 1: Specification applies for $T_A = 25^\circ\text{C}$ with + 12V on Pins 1 and 2; − 12V on Pins 6 and 7 for the metal can package and + 12V on Pins 1 and 2; − 12V on Pins 4 and 5 for the dual-in-line package, unless otherwise specified. The parameter guarantees for LH0002C apply over the temperature range of 0°C to + 85°C, while parameters for the LH0002 are guaranteed over the temperature range − 55°C to + 125°C unless otherwise specified.

Note 2: Refer to RETS0002X for LH0002 military specifications.

Note 3: Absolute Maximum Ratings indicate limits beyond which damage to the device may occur. Operating Ratings indicate conditions for which the device is intended to be functional, but do not guarantee specific performance limits. For guaranteed specifications and test conditions, see the Electrical Characteristics. The guaranteed specifications apply only for the test conditions listed.

Note 4: The maximum power dissipation is a function of maximum junction temperature ($T_{J\text{Max}}$), total thermal resistance (θ_{JA}), and ambient temperature (T_A). The maximum allowable power dissipation at any ambient is $P_D = (T_{J\text{Max}} - T_A)/\theta_{JA}$.

Note 5: For operating at elevated temperatures, the device must be derated based on the thermal resistance θ_{JA} and $T_{J\text{Max}}$. $T_J = T_A + P_D\theta_{JA}$.

Note 6: Human body model, 1.5 k Ω in series with 100 pF.

Typical Applications

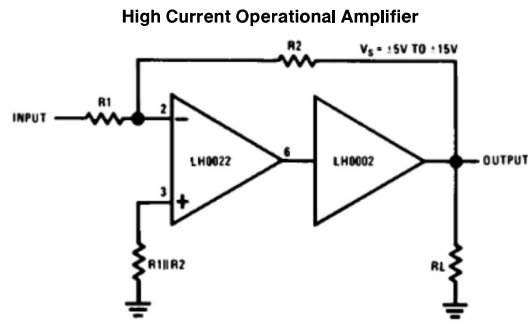

TL/H/5560-4

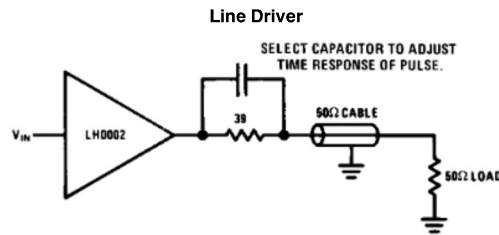

*Previously called NH0002/NH0002C

TL/H/5560-5

Typical Performance Characteristics

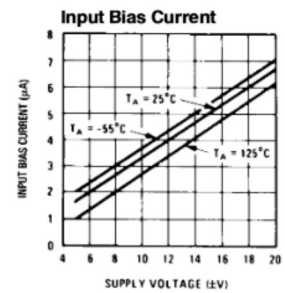
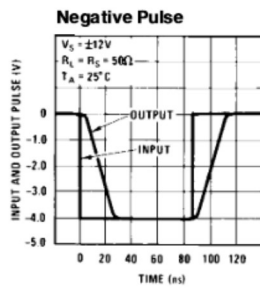
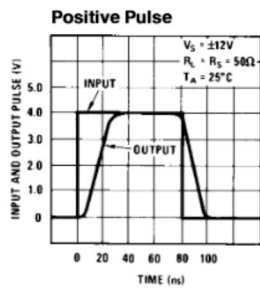
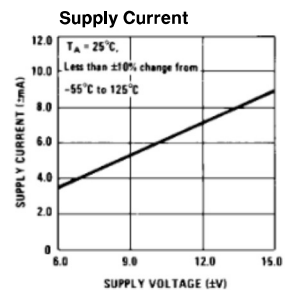
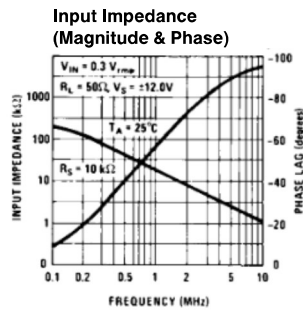
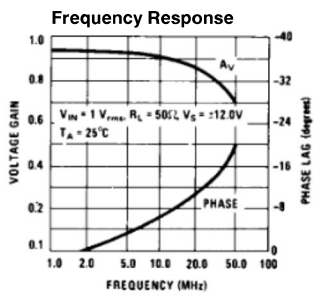

TL/H/5560-7

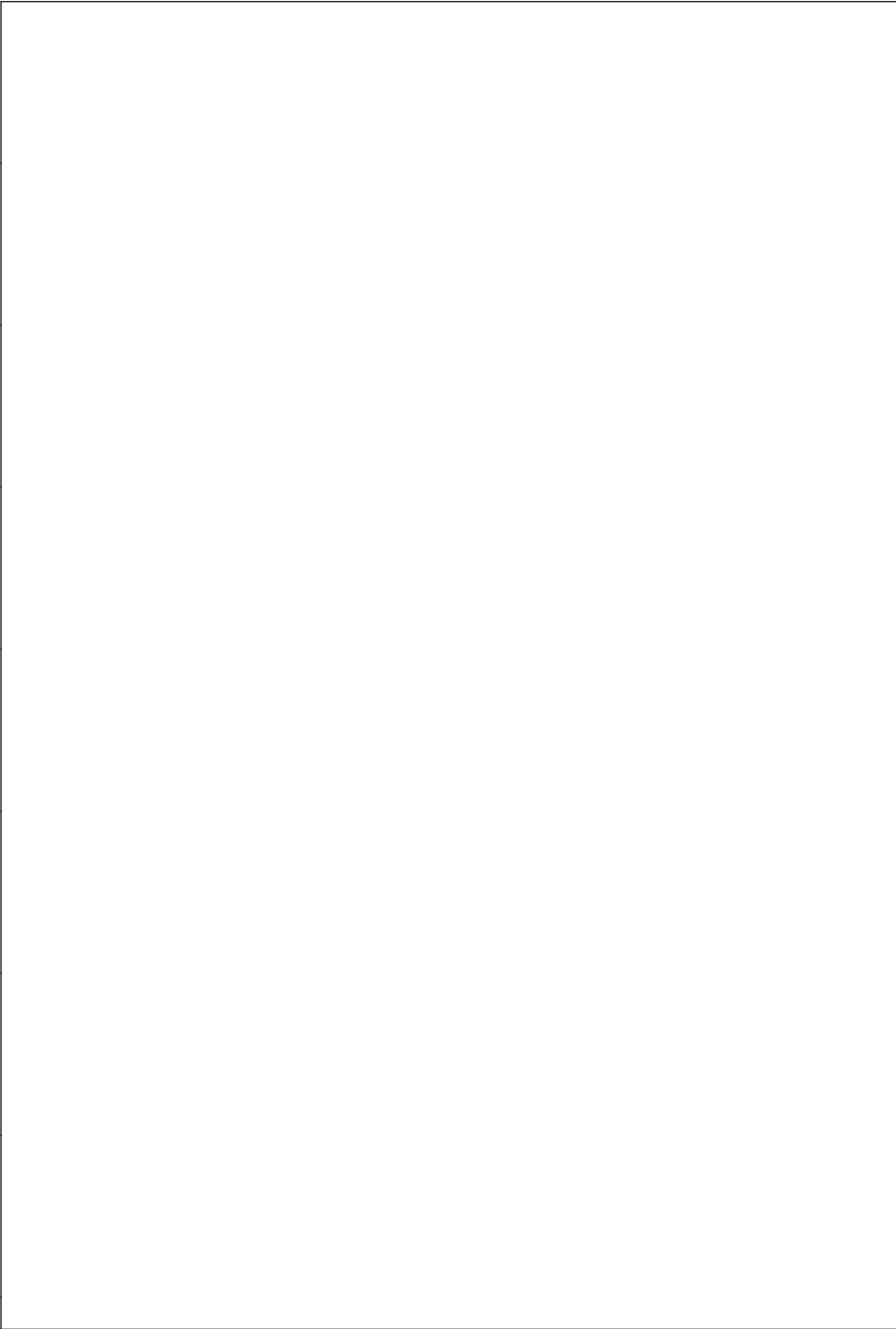

Physical Dimensions inches (millimeters)

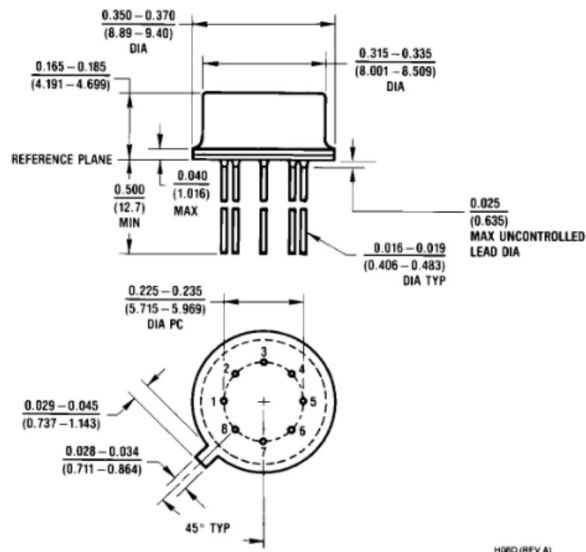

H08D (REV A)

Metal Can Package (H)
Order Number LH0002H, LH0002H-MIL, LH0002H/883 or LH0002CH
NS Package Number H08D

Physical Dimensions inches (millimeters) (Continued)

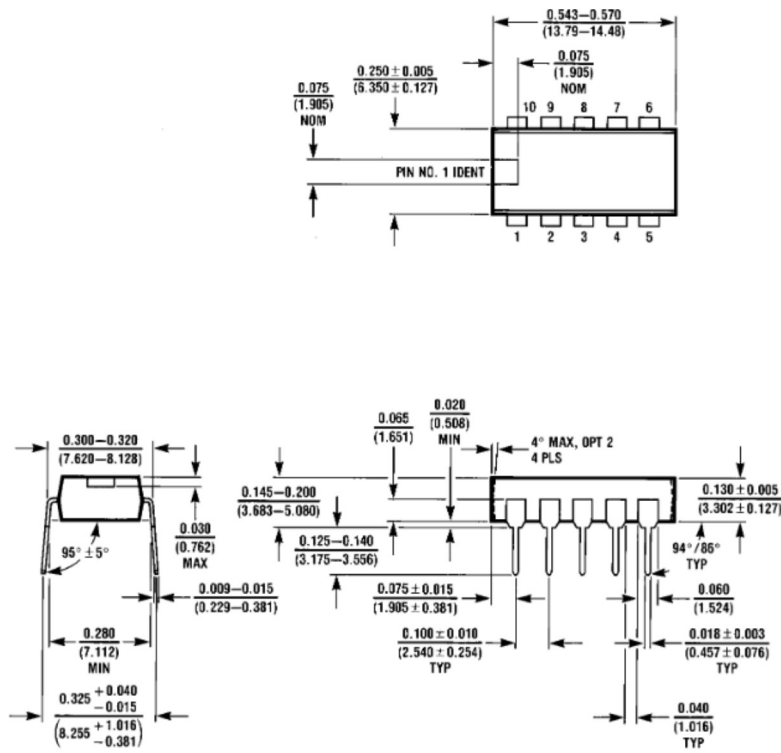

Molded Dual-In-Line Package (N)
 Order Number LH0002CN
 NS Package Number N10A

N10A (REV A)

LIFE SUPPORT POLICY

NATIONAL'S PRODUCTS ARE NOT AUTHORIZED FOR USE AS CRITICAL COMPONENTS IN LIFE SUPPORT DEVICES OR SYSTEMS WITHOUT THE EXPRESS WRITTEN APPROVAL OF THE PRESIDENT OF NATIONAL SEMICONDUCTOR CORPORATION. As used herein:

1. Life support devices or systems are devices or systems which, (a) are intended for surgical implant into the body, or (b) support or sustain life, and whose failure to perform, when properly used in accordance with instructions for use provided in the labeling, can be reasonably expected to result in a significant injury to the user.
2. A critical component is any component of a life support device or system whose failure to perform can be reasonably expected to cause the failure of the life support device or system, or to affect its safety or effectiveness.



National Semiconductor Corporation
 1111 West Bardin Road
 Arlington, TX 76017
 Tel: 1(800) 272-9959
 Fax: 1(800) 737-7018

National Semiconductor Europe
 Fax: (+49) 0-180-530 85 86
 Email: cnjwge@tevm2.nsc.com
 Deutsch Tel: (+49) 0-180-530 85 85
 English Tel: (+49) 0-180-532 78 32
 Français Tel: (+49) 0-180-532 93 58
 Italiano Tel: (+49) 0-180-534 16 80

National Semiconductor Hong Kong Ltd.
 13th Floor, Straight Block,
 Ocean Centre, 5 Canton Rd.
 Tsimshatsui, Kowloon
 Hong Kong
 Tel: (852) 2737-1600
 Fax: (852) 2736-9960

National Semiconductor Japan Ltd.
 Tel: 81-043-299-2309
 Fax: 81-043-299-2408