

REVISIONS			
ISS	ZONE	DESCRIPTION\PER REQUEST\DATE	

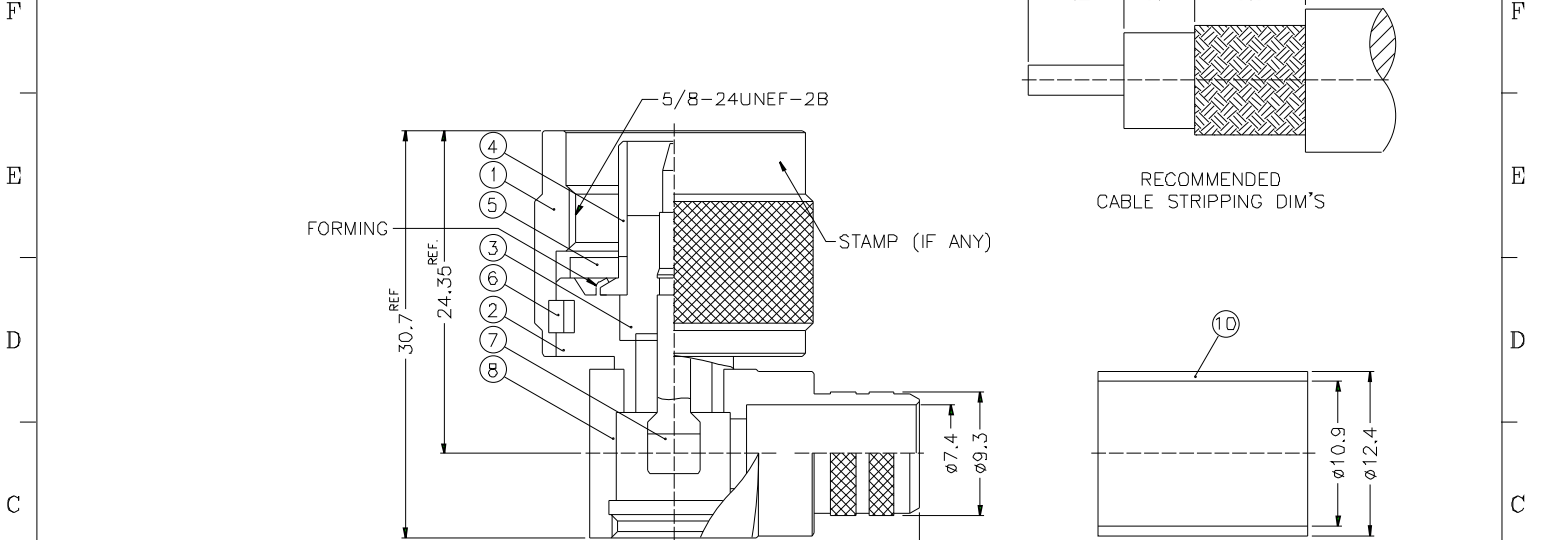

NOTES: FINISH (PLATING THICKNESS IN MICRO-INCHES)
 1. BRASS PER QQ-B-626
 2. NICKEL PL. 100 MIN. THICK OVER COPPER STRIKE
 3. GOLD PL. 3 MIN. THICK OVER NICKEL PL. 100 MIN. THICK OVER COPPER STRIKE
 4. TEFLON MIL-P-19468
 5. JIS H3250, C 2700

NO.	DESCRIPTION	MATERIAL	FINISH	QTY	DRAWING NO.
10	FERRULE	NOTE 5	NOTE 2	1	FR-124/109X158
9	NUT	NOTE 1	NOTE 2	1	B5291-14-28
8	BARREL	NOTE 1	NOTE 2	1	N1112B2-8-93 /74
7	CONTACT PIN	NOTE 1	NOTE 3	1	N1112B2-7
6	RETAINER RING	SUS 304	NATURAL	1	N5000-7-C
5	GASKET	SILICONE	RED	1	GS-156/8X15
4	CONTACT BODY	NOTE 1	NOTE 2	1	N5000-5
3	INSULATOR	NOTE 4	NATURAL	1	N1112A2-3
2	BODY	NOTE 1	NOTE 2	1	N1112B1-2
1	SHELL	NOTE 1	NOTE 2	1	N5000-1-B

DIMENSIONS ARE IN MILLIMETERS		PART NO.	N1112B2-002-NT3G-7-50
UNLESS OTHERWISE SPECIFIED TOLERANCES		APPROVED	DATE
0.5-6 = ±0.2			10-11-01'
6-30 = ±0.4		CHECKED	DATE
30-120 = ±0.6			10-11-01'
120-315 = ±1		DRAWN	DATE
315-1000 = ±1.6			10-11-01'
1000-2000 = ±2.4		FILE NO.	

RECOMMENDED CABLE STRIPPING DIM'S

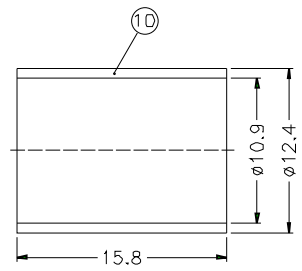

1. CRIMPED FERRULE
HEX CRIMP SIZE .429"
2. CONTACT PIN TO SOLDER

Amphenol

TITLE N R/A CRIMP PLUG
(FOR RG-8/U,213/U)

DRAWING NO. KJ-N1112B2-002-NT3G-8U-50

ITEM NO.