

CABLE CLAMP FOR FLEXIBLE CABLES

SQUARE FLANGE JACK

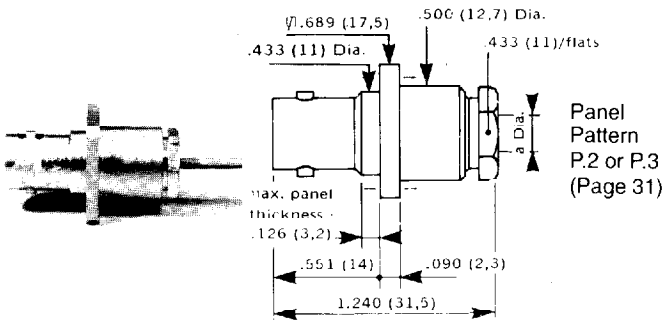

CABLE DIA. Ω	$.079$ (2) 50	$.102$ (2,6) 50 + 75	$.102$ (2,6) 50 + 75
PART NUMBER	R 141 253	R 141 254	R 141 278
a dia. max.	$.087$ (2,2)	$.116$ (2,95)	$.116$ (2,95)
Captive contact	YES	YES	YES
Flange holes	4 holes N° 3.56 UNF.2B (M2,5 x 0,45)		4 holes .102 dia (\varnothing 2,6)
Assembly	M 04	M 04	M 04

SQUARE FLANGE JACK

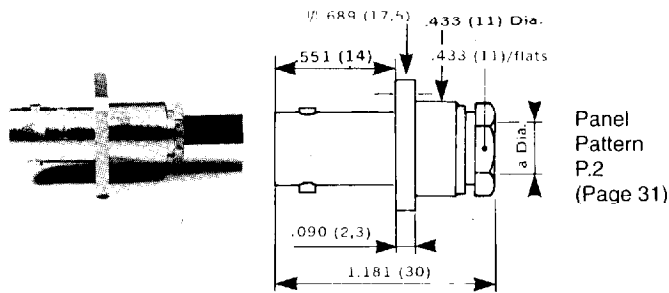

CABLE DIA. Ω	$.138$ (3,5) 50 + 75	$.197$ (5) 50	$.236$ (6) 75 + 93
PART NUMBER	R 141 255	R 141 257	R 141 261
Equival. MIL		UG. 291/U	UG. 262/U
a dia. max.	$.146$ (3,7)	$.220$ (5,6)	$.256$ (6,5)
Captive contact	NO	NO	NO
Flange holes	4 holes N° 3.56 UNF.2B (M 2,5 x 0,45)		
Assembly	M 01	M 01	M 01

SQUARE FLANGE JACK

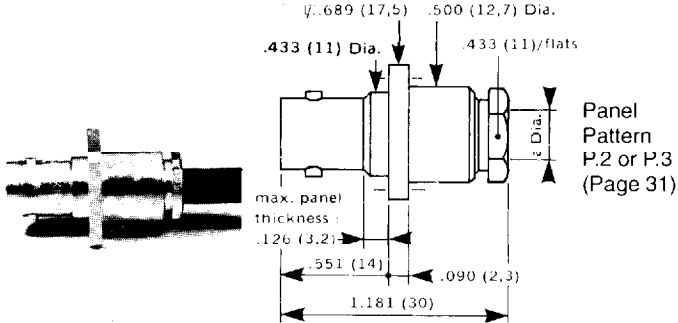

CABLE DIA. Ω	$.197$ (5) 50	$.236$ (6) 75 + 93	
PART NUMBER	R 141 258	R 141 259	R 141 262
Equival. MIL	UG. 291 C/U		UG. 262 C/U
Equival. NF	KBN 3		KBN 13
a dia. max.	$.220$ (5,6)	$.220$ (5,6)	$.256$ (6,5)
Captive contact	NO	NO	NO
Flange holes	4 holes N° 3.56 UNF.2B (M 2,5 x 0,45)	4 holes .102 dia. (\varnothing 2,6)	4 holes N° 3.56 UNF.2 (M 2,5 x 0,45)
Assembly	M 02	M 02	M 02

INSULATED SQUARE FLANGE JACK

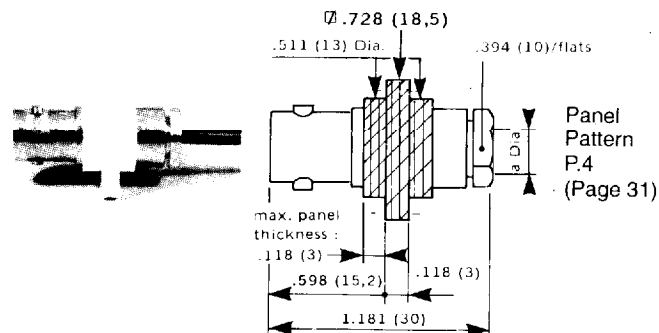

CABLE DIA. Ω	$.102$ (2,6) 50 + 75
PART NUMBER	R 141 277
a dia. max.	$.116$ (2,95)
Captive contact	YES
Flange holes	4 holes .102 dia (\varnothing 2,6)
Assembly	M 04

INSULATED SQUARE FLANGE JACK

CABLE DIA.	.197 (5)	.236 (6)
Ω	50	75 +93
PART NUMBER	R 141 256	R 141 264
a dia. max.	.220 (5,6)	.256 (6,5)
Captive contact	NO	NO
Flange holes	4 holes .102 dia. (Ø2,6)	
Assembly	M 01	M 01

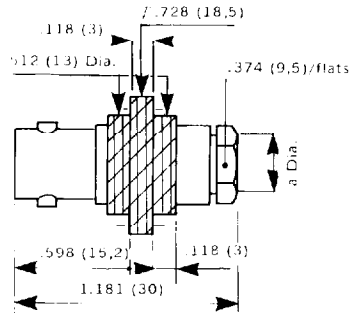

Panel Pattern P.4 (Page 31)



STRAIGHT BULKHEAD JACK

CABLE DIA.	.102 (2,6)	
Ω	50 + 75	
PART NUMBER	R 141 304	
a dia. max.	.116 (2,95)	
Captive contact	YES	
Assembly	M 04	

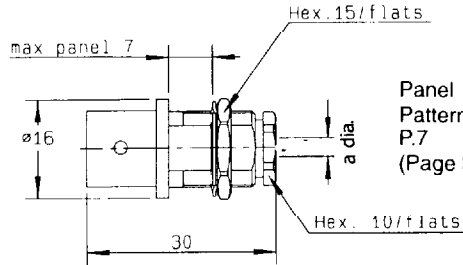

Panel Pattern P.7 (Page 31)



STRAIGHT BULKHEAD JACK WITH PANEL SEAL

CABLE DIA.	.079 (2)	.102 (2,6)
Ω	50	50 + 75
PART NUMBER	R 141 323	R 141 324
a dia. max.	.087 (2,2)	.116 (2,95)
Captive contact	YES	YES
Assembly	M 04	M 04

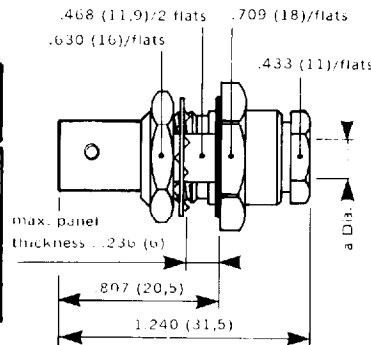

Panel Pattern P.7 (Page 31)



STRAIGHT BULKHEAD JACK WITH PANEL SEAL

CABLE DIA.	.197 (5)	.236 (6)
Ω	50	75 +93
PART NUMBER	R 141 327	R 141 329
a dia. max.	.220 (5,6)	.260 (6,6)
Captive contact	NO	NO
Assembly	M 02	M 02

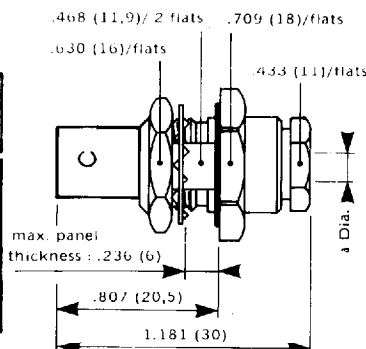

Panel Pattern P.7 (Page 31)

