

**TWO INSULATED WASHERS**

**PACKAGING PER 100**

**R280.902.000**

Series : ACC-COAX

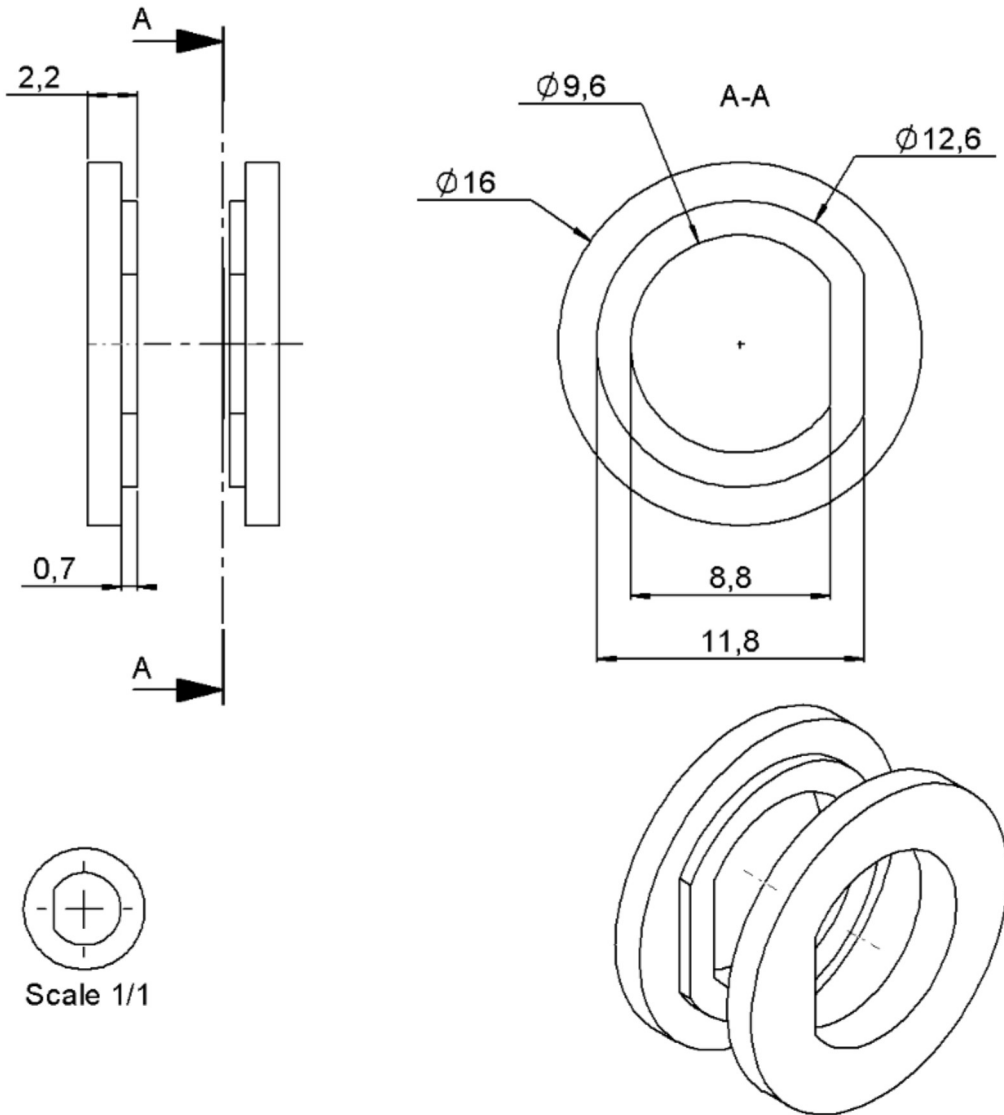

All dimensions are in mm.



COMPONENTS	MATERIALS	PLATING (µm)
BODY	white Nylon 20% glass fiber	-
CENTER CONTACT	-	-
OUTER CONTACT	-	-
INSULATOR	-	-
GASKET	-	-
OTHERS PARTS	-	-
-	-	-
-	-	-

Issue : 0726 A

In the effort to improve our products, we reserve the right to make changes judged to be necessary



**TWO INSULATED WASHERS**

**R280.902.000**

**PACKAGING PER 100**

Series : ACC-COAX

**PACKAGING**

Standard	Unit	Other
	'W' option	Contact us

**SPECIFICATION**

**CABLE ASSEMBLY**

Stripping	a	b	c	d	e	f
mm						

**ELECTRICAL CHARACTERISTICS**

Impedance		$\Omega$
Frequency		GHz
VSWR	+	x F(GHz) Maxi
Insertion loss		$\sqrt{F}$ (GHz) dB Maxi
RF leakage	- (	-F(GHz)) dB Maxi
Voltage rating		Veff Maxi
Dielectric withstanding voltage		Veff mini
Insulation resistance		M $\Omega$ mini

Assembly instruction :

Recommended cable(s)

**MECHANICAL CHARACTERISTICS**

Recommended torque		
Panel nut		N.cm
Clamp nut		N.cm
A/F clamp nut		mm
Mating life		Cycles mini
Weight	<b>0,5300</b>	g

Cable retention

- pull off

N mini

- torque

N.cm

**TOOLING**

Part Number	Description	Hexagon
.	.	.

**OTHER CHARACTERISTICS**

-

**ENVIRONMENTAL**

Operating temperature	- °C
Panel leakage	

Issue : 0726 A

In the effort to improve our products, we reserve the right to make changes judged to be necessary

